

REGAL MODEL SC401 DUAL CYLINDER SCALE

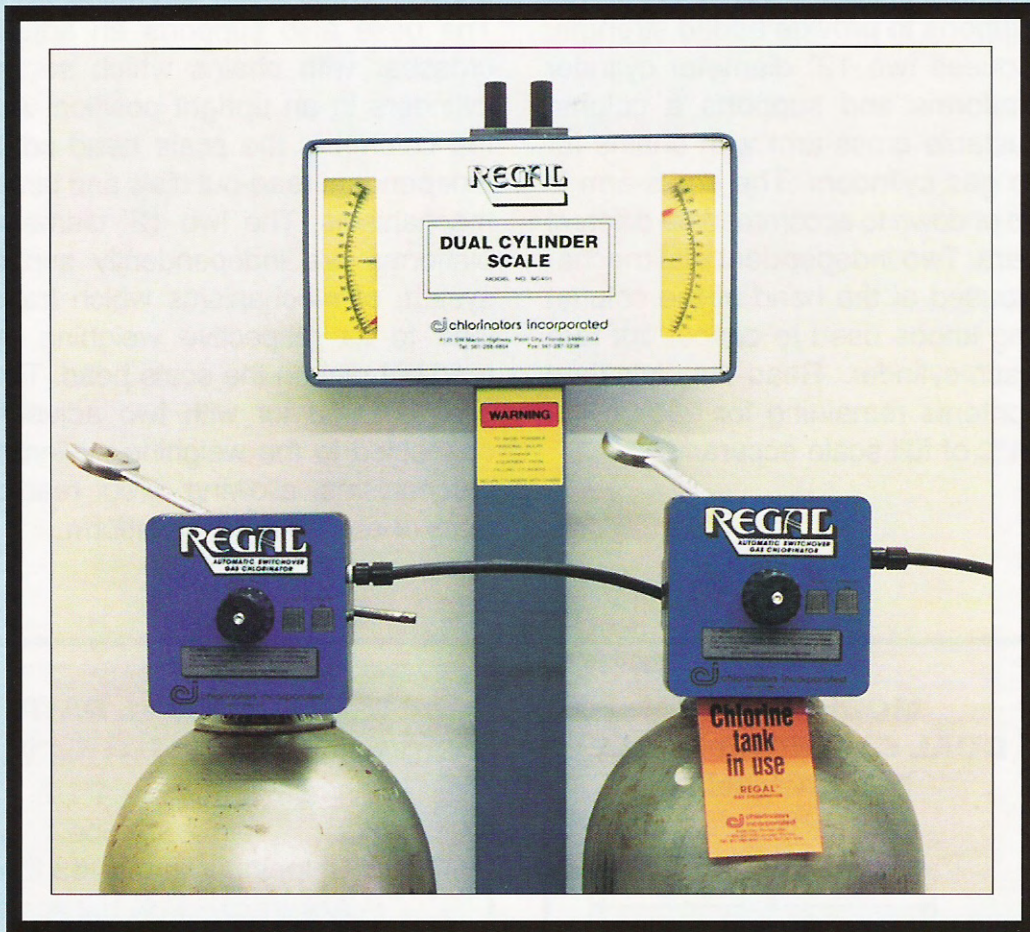

FEATURES:

- Surpasses industry standards for two-cylinder scales
 - Two independent mechanical scales in one unit
 - UPS shippable...Shipping weight under 65 lbs.
 - Easy on-site assembly and installation
 - Factory calibrated
 - Adjustable cross-arm with chains to secure cylinders
- 1 1/2" high PVC base and weighing discs eliminates corrosion caused by sweating cylinders
- Easy to read 5" scale length with 150 graduations allows for 1/2 lb. readability

REGAL
GAS CHLORINATOR

DESCRIPTION

The REGAL Model SC401 dual cylinder scale independently weighs the contents of two compressed gas cylinders simultaneously. The 1-1/2" high PVC base is constructed with adequate supports to provide added strength. The base houses two 12" diameter cylinder weighing platforms and supports a column with an adjustable cross-arm with chains for securing the gas cylinders. The cross-arm is adjustable up or down to accommodate different sized cylinders. Two independent dial mechanisms are housed at the head of the column with adjusting knobs used to cancel out tare weight for each cylinder. Read-out dials then show net contents remaining for each cylinder within $\pm 1\%$ of full scale accuracy.

DESIGN AND CONSTRUCTION

The REGAL Model SC401 dual cylinder scale is an improved design consisting of a reinforced 1-1/2" high PVC base with two weighing platforms, each operating independently. The base also supports an adjustable steel crossbar with chains which secure the gas cylinders in an upright position. At the top of the column is the scale head containing two independent read-out dials and tare adjustment mechanisms. The two 12" diameter weighing platforms are independently supported by a system of mechanisms which transmits each load to its respective weighing system and read-out dial on the scale head. Tare weight is compensated for with two adjustment knobs connected to the weighing system with spring mechanisms, allowing direct read-out of contents of each weighing platform.

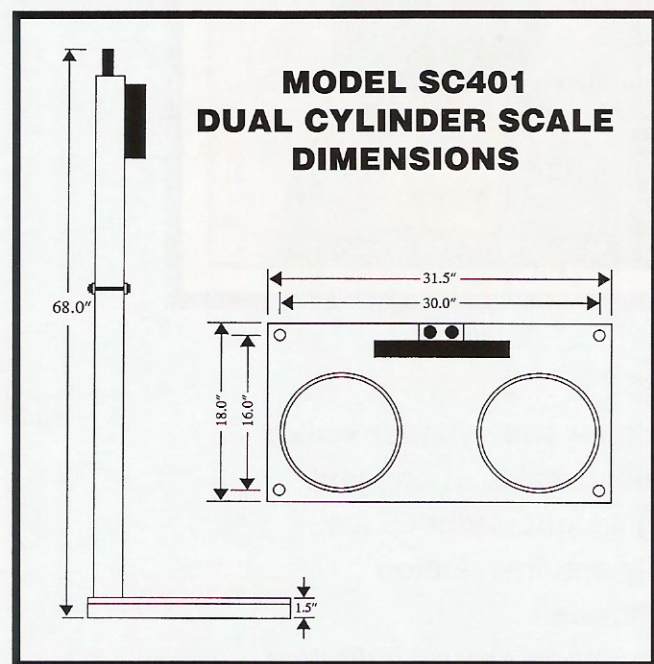

TECHNICAL DATA

Dimensions - 68"H, 31 1/2"W, 18"D
Base Height - 1 1/2"
Weight - 55 lbs.
Shipping Weight - 63 lbs.
Accuracy - $\pm 1\%$ full scale

CYLINDER SIZE AND WEIGHT

Standard 150 lb. chlorine cylinder and other cylinders 12" or less diameter with gross weight of 300 lbs or less. Net content weight to maximum of 150 lbs. Tare weight 80-150 lbs. Operating temperature range: 0-120°F



chlorinators incorporated

1044 SE Dixie Cutoff Road, Stuart, FL 34994 USA

Tel: 772-288-4854 • Fax: 772-287-3238 • www.regalchlorinators.com •

regal@regalchlorinators.com