



Industrial Water Solutions

NRO-4V Series &

NRO-4H Series



PACKAGED REVERSE OSMOSIS SYSTEMS

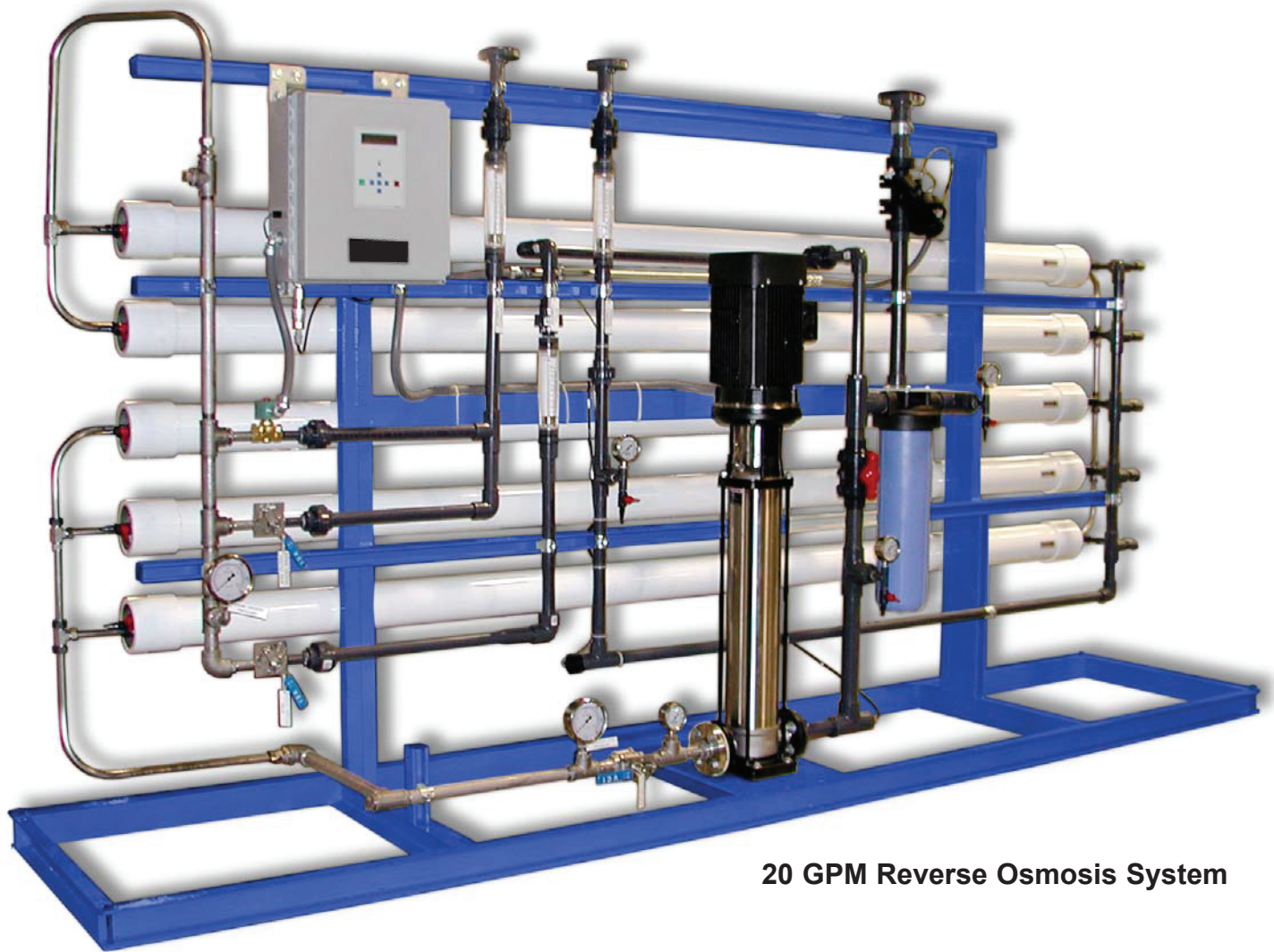

20 GPM Reverse Osmosis System



1-800-820-9021



info@industrialh2osolutions.com

Industrial Water Solutions

PRODUCT OVERVIEW

The NRO Series Commercial and Industrial Reverse Osmosis Systems are engineered to economically produce high purity water by removal of dissolved minerals, bacteria, particles, and organic impurities. Each NRO machine is constructed using the highest quality components and materials for reliable operation and exceptional performance. Standard machines in the NRO-4 Series are available with product water capacities from 2.5–20 GPM (3,600–28,800 GPD). Contact Marlo for larger flow requirements with the MRO-8 Series equipment.

IWS Reverse Osmosis Systems provide exceptional performance in a wide variety of applications, including:

- Boiler Feedwater
- Electronics Manufacturing
- Chemical Manufacturing
- Ink/Dye Production
- Metal Plating/Finishing
- Food/Beverage Production
- Ice-Making Plants
- Deionization Pre-Treatment
- Bottled Water Production
- Hospital/Medical Facilities
- Research Laboratories
- Greenhouses and Nurseries
- Humidification
- General Potable Water



NRO-4H Series (10,800–16,200 GPD)



NRO-4V Series (3600–9000 GPD)

SYSTEM OPTIONS

IWS Reverse Osmosis Systems NRO-3600-4V through NRO-16200-4H models are available skid-mounted, pre-piped, and pre-wired with the following pre-treatment and post-treatment equipment for a complete water treatment package. Skid-mounted units provide maximum efficiency of floor space and reduced installation costs.

- Multi-Media and Activated Carbon Pre-Filtration Systems
- RO Water Atmospheric Storage Tanks
- Inlet Feed Water Chemical Injection Systems
- Membrane Clean-in-Place (CIP) Systems
- UV Sterilization Post-Treatment Systems
- Water Softener Pre-Treatment Systems
- RO Water Pressurized Storage Tanks
- Repressurization Pumps and Controls
- Deionization (DI) Polisher Systems
- Sub-Micron Final Filter Housings

... DESIGNED FOR PERFORMANCE

SPECIFICATIONS—NRO-3600-4V THROUGH NRO-9000-4V SERIES

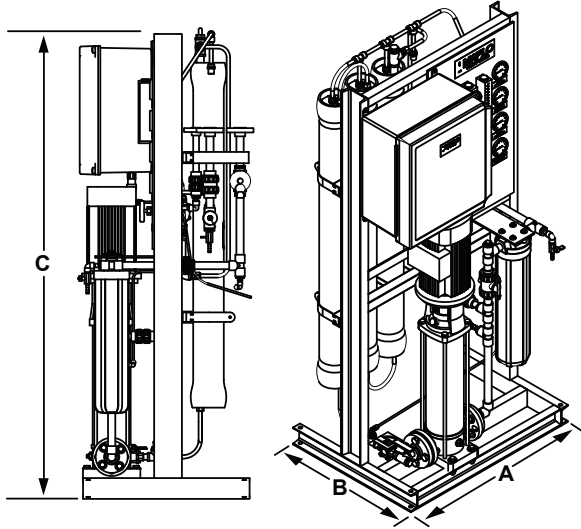

The NRO-4V series RO systems are available with nominal capacities from 3,600 to 9,000 gallons/day. These units are designed for commercial and industrial applications and feature the following as standard equipment:

- High rejection 4"×40" RO membranes in stainless steel pressure vessels.
- Microprocessor controller package with NEMA-4X enclosures.
- Stainless steel multistage centrifugal high pressure pumps.
- TEFC high efficiency motor, 208-230/460 VAC, 3 phase.
- Polypropylene pre-filter housing material.
- Fully-panel mounted system flow meters and pressure gauges.
- Digital RO product water conductivity meter.
- Actuated automatic RO system inlet feed valve.
- RO reject and recycle flow control valves.
- Automatic system flush on shutdown.
- Epoxy coated carbon steel skid/frame of welded construction.
- Optional motor starter disconnect switch.
- Optional skid mounted pre/post treatment equipment.

Model No.	Design (gpm)	Capacity (gpd)	Element Quantity	RO Feed (gpm)	RO Reject (gpm)	System Piping Connections			Nominal Operating Pressure	Pump Hp	Approx. Ship Wt.
						Inlet Feed	Permeate	RO Reject			
NRO-3600-4V	2.5	3,600	2	3.3-3.8	.8-1.3	¾" Flange	½" Flange	½" Flange	251 psi	3.0	425 lb.
NRO-5400-4V	3.8	5,400	3	5.0-5.8	1.2-2.0	¾" Flange	½" Flange	½" Flange	242 psi	3.0	475 lb.
NRO-7200-4V	5.0	7,200	4	6.7-7.7	1.7-2.7	¾" Flange	¾" flange	½" Flange	235 psi	5.0	525 lb.
NRO-9000-4V	6.3	9,000	5	8.4-9.7	2.1-3.4	¾" Flange	¾" Flange	½" Flange	230 psi	5.0	575 lb.

Model No.	Length A	Width B	Height C
NRO-5400-4V	36"	24"	68"
NRO-7200-4V	36"	30"	68"
NRO-9000-4V	36"	30"	68"

SPECIFICATIONS—NRO-10800-4H THROUGH NRO-16200-4H SERIES

The NRO-10800 through 16200-4H series RO systems are available with nominal capacities from 10,800 to 16,200 gallons/day. These units are designed for commercial and industrial applications and feature the following as standard equipment:

- High rejection 4" x 40" RO membranes in FRP pressure vessels.
- Microprocessor controller package with NEMA-4X enclosures.
- Stainless steel multistage centrifugal high pressure pumps.
- TEFC high efficiency motor, 208-230/460 VAC, 3 phase.
- Polypropylene pre-filter housing material.
- Fully-panel mounted system flow meters and pressure gauges.
- Digital RO product water conductivity meter.
- Actuated automatic RO system inlet feed valve.
- RO reject and recycle flow control valves.
- Automatic system flush on shutdown.
- Epoxy coated carbon steel skid/frame of welded construction.
- Optional motor starter disconnect switch.
- Optional skid mounted pre/post treatment equipment.

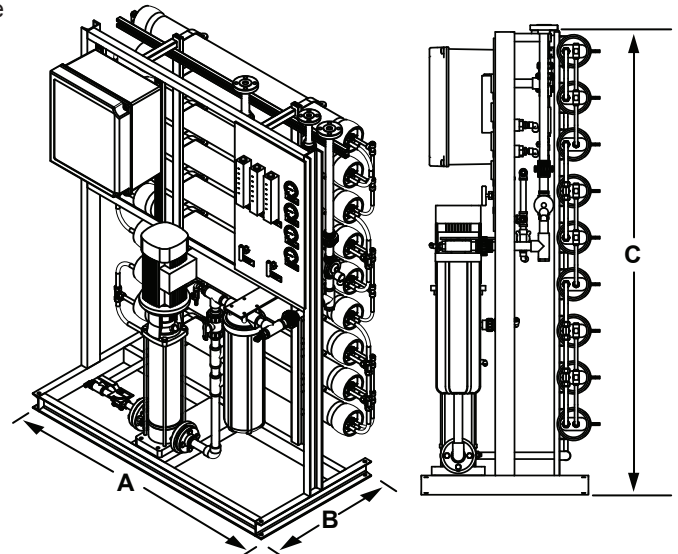

Model No.	Design (gpm)	Capacity (gpd)	Element Quantity	RO Feed (gpm)	RO Reject (gpm)	System Piping Connections			Nominal Operating Pressure	Pump Hp	Approx. Ship Wt.
						Inlet Feed	Permeate	RO Reject			
NRO-10800-4H	7.5	10,800	6	10.0-11.5	2.5-4.0	1" Flange	¾" Flange	½" Flange	251 psi	5.0	650 lb.
NRO-12600-4H	8.8	12,600	7	11.7-13.5	2.9-4.7	1" Flange	¾" Flange	½" Flange	242 psi	5.0	700 lb.
NRO-14400-4H	10.0	14,400	8	13.3-15.4	3.3-5.4	1" Flange	¾" flange	¾" Flange	234 psi	5.0	750 lb.
NRO-16200-4H	11.3	16,200	9	15.0-17.4	3.7-6.1	1" Flange	1" Flange	¾" Flange	234 psi	5.0	800 lb.

Model No.	Length A	Width B	Height C
NRO-12600-4H	54"	26"	76"
NRO-14400-4H	54"	26"	76"
NRO-16200-4H	54"	26"	76"

SPECIFICATIONS—SERIES NRO-18K-4H THROUGH NRO-29K-4H

Model No.	Design (gpm)	Capacity (gpd)	Element Quantity	RO Feed (gpm)	RO Reject (gpm)	System Piping Connections			Nominal Operating Pressure	Pump Hp	Approx. Ship Wt.
						Inlet Feed	Permeate	RO Reject			
NRO-18K-4H	12.5	18,000	12	16.7–19.2	4.2–6.7	1½" Flange	1" Flange	¾" Flange	280 psi	7.5	1050 lb.
NRO-22K-4H	15.0	21,600	15	20.0–23.0	5.0–8.0	1½" Flange	1" Flange	¾" Flange	270 psi	7.5	1200 lb.
NRO-25K-4H	17.5	25,200	18	23.2–26.8	5.7–9.3	1½" Flange	1½" Flange	¾" Flange	260 psi	10	1350 lb.
NRO-29K-4H	20.0	28,800	21	26.7–30.8	6.7–10.8	1½" Flange	1½" Flange	1" Flange	245 psi	10	1500 lb.

The NRO-18K-4H through NRO-29K-4H series Reverse Osmosis membrane systems are available with nominal product capacities from 12.5 GPM to 20 GPM (18,000 GPD to 28,800 GPD). The units are designed for commercial and industrial applications and feature the following as standard equipment:

- High rejection 4"×40" RO membranes in FRP pressure vessels.
- Microprocessor controller package with NEMA-4X enclosure.
- Stainless steel multistage centrifugal high pressure pump.
- TEFC high efficiency motor, 208-230/460 VAC, 3-Phase.
- Polypropylene pre-filter housing material.
- Panel mounted instrumentation including digital RO product water conductivity and system pressure gauges.
- In-line flowmeters for RO product, RO reject to drain, and RO recirculation flows.
- Actuated automatic RO system inlet feed valve.
- Stainless steel RO reject and recycle flow control valves.
- Automatic system flush on shutdown or timed intervals.
- Epoxy coated carbon steel skid/frame of welded construction.
- RO membrane clean-in-place (CIP) isolation valving and quick-connect cleaning ports.
- Optional motor starter disconnect switch.

OVERALL SYSTEM DIMENSIONS NRO-18K-4H THROUGH NRO-29K-4H

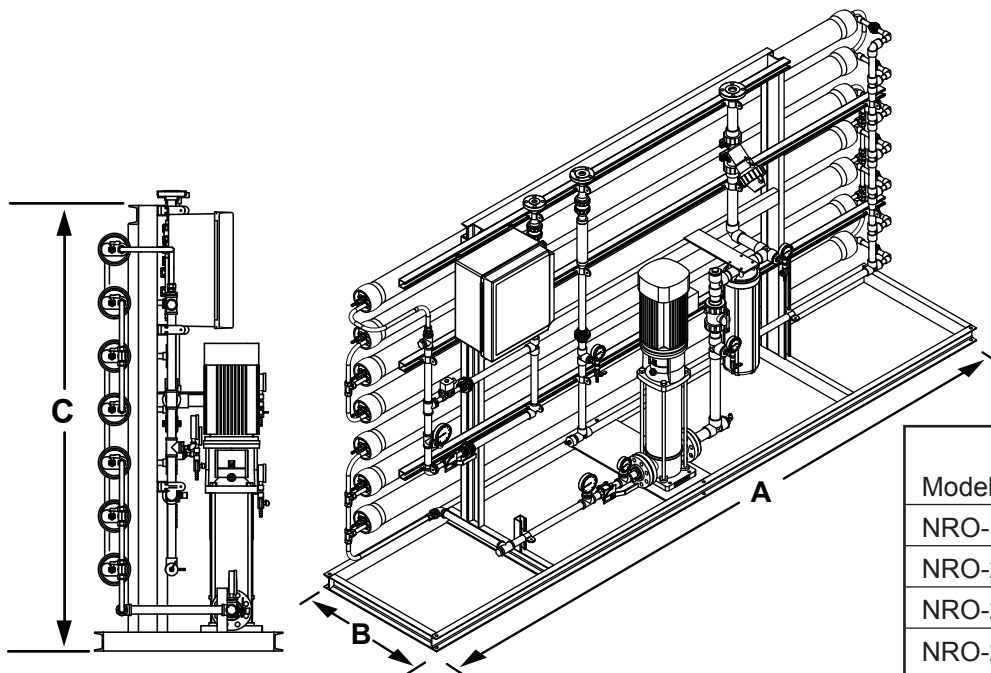

Model No.	Length A	Width B	Height C
NRO-18K-4H	144"	30"	76"
NRO-22K-4H	144"	30"	76"
NRO-25K-4H	144"	30"	76"
NRO-29K-4H	144"	30"	76"

SYSTEM OPERATING PARAMETERS

Operating Pressures: 230–280 PSIG
 Minimum Inlet Pressure: 30 PSIG
 Operating Temperature Range: 35–85°F.
 Maximum Inlet Free Chlorine: <0.1 PPM
 Maximum Inlet Silt Density Index (SDI): 3.0

Nominal System Recovery Rate: 65–75%
 Nominal System TDS Rejection: 95–99%
 RO Pump Electrical Requirements: 460 VAC, 3-Phase, 60 Hz.
 Control Panel Electrical Requirements: 120 VAC, 1-Phase, 60 Hz.
 Operations and performance based on inlet feed of softened water of 2,000 PPM at 77°F.



1-800-820-9021



info@industrialh2osolutions.com